

# EZIHEAT

SMART HEATING SOLUTIONS

## SERENITY

### INVERTER POOL HEAT PUMP

### USER MANUAL



## Table of contents

<b>A. Foreword</b>	<b>1</b>
<b>B. Safety Precautions</b>	<b>2</b>
1. Warning	2
2. Attention	3
3. Safety	3
<b>C. About your heat pump</b>	<b>4</b>
1. Transportation	4
2. Accessories	4
3. Features	5
4. Operating range	5
5. Introduction of different modes	5
6. Technical parameter	6
7. Dimension	7
<b>D. Installation guidance</b>	<b>8</b>
1. Installation reminder	8
2. Wiring	11
3. Electric wiring diagram	12
4. References for protecting devices and cable specification	12
<b>E. Operation guidance</b>	<b>13</b>
1. Touchpad Functions	13
2. Operation Instructions	13
<b>F. Testing</b>	<b>15</b>
1. Inspect heat pump before use	15
2. Leakage detection notice and method	15
3. Trial	16
<b>G. Maintenance</b>	<b>17</b>
<b>H. Trouble shooting for common faults</b>	<b>18</b>
<b>I. Water pump control connection</b>	<b>20</b>
<b>J. Wi-Fi operation</b>	<b>24</b>

## A. Foreword

---

Thank you for choosing the EZIHEAT high efficiency inverter pool heat pump. All EZIHEAT heat pumps are designed and built using the most advanced technology to the highest standards.

Before attempting to install your pool heat pump please read and understand all the important information provided in this manual.

It is important that you register your heat pump for our peace of mind warranty to apply. This can easily be done online here - <https://eziheat.com.au/warranty-registration/>

We pride ourselves on quality and service so if you have any technical questions or require any further information please contact our friendly team at [support@eziheat.com.au](mailto:support@eziheat.com.au)

We hope you'll enjoy using our energy saving heat pumps.

Thank you – The EZIHEAT Team

### HEAT PUMP INFORMATION RECORD

Heat Pump Model: \_\_\_\_\_

Heat Pump Serial Number: \_\_\_\_\_

Date of Installation: \_\_\_\_\_

Installer Information: \_\_\_\_\_

Notes:

## B. Safety Precautions

---

We have provided important safety messages in this manual for the installation, maintenance and repair on your heat pump.

Please read, take note and obey all safety messages.

**Environment friendly R32 Refrigerant is used in this heat pump**

### 1. Warning

---



The WARNING sign denotes a hazard. It calls attention to a procedure, practice, or the like, which, if not correctly performed or adhered to, could result in personal injury or injury to a third party. These signs are rare, but are extremely important.

	1. Keep the heat pump away from fire sources.
	b. The heat pump must be placed in a well-ventilated area, outdoors. Indoor or enclosed areas are not allowed and will void your warranty.
	c. Repair and disposal must be carried out by a trained authorised service personnel
	d. Vacuum the system completely before welding. Welding should only be carried out by professionally trained/licenced personnel.

## 2. Attention – Important Safety Instructions

---

- a. Please read the following instructions before installation, use and maintenance.
- b. Installation must be only be completed by competent or professional persons only in accordance with this manual.
- c. Once installed check all water connections for leaks. All pipework connections must be sealed and tested before operation of the heat pump.
- d. Please don't stack substances, which will block air flow near/around the heat pump area. This will cause the efficiency of the heat pump to reduced or even stopped.
- e. Correctly set temperature is required for personal preference making sure to avoid overheating or over cooling.
- f. Do not use or stack combustible gas or liquid such as thinners, paint, fuel or pool chemicals to avoid fire.
- g. Except for the methods recommended by the manufacturer, do not use any methods to accelerate the defrosting process or clean the frosted parts.
- h. In order to optimise the heating effect, please install heat preservation insulation on pipes between swimming pool and heat pump, and please use a recommended pool cover on the swimming pool.
- i. Connecting pipes from the swimming pool to the heat pump should be less than 10m.
- j. If a repair is required, please contact the EZIHEAT team [support@eziheat.com.au](mailto:support@eziheat.com.au) All repair practiced by non-professional/licenced persons is prohibited.

## 3. Safety

---

- a. Please keep the main power supply switch out of reach from children.
- b. When a power blackout/cut occurs during operation, and later the power is restored, the heat pump will start-up automatically.
- c. Please switch off the mains power supply in high storm weather conditions to prevent heat pump damage caused by lightning strikes.
- d. Safety inspections must be carried out before maintenance or repair for heat pumps with R32 gas in order to minimise the risk.
- e. During installation of the heat pump if you notice any R32 gas leak stop the installation and call EZIHEAT on 1300 363 555 or your nearest service centre.
- f. Any repairs should be carried out in a well-ventilated area. Any source of ignition is prohibited during the inspection.

## C. About your heat pump

---

### 1. Transportation

---

a. Always keep upright

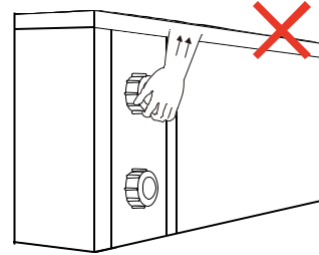
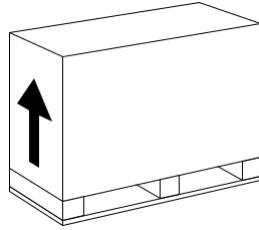

b. Do not lift heat pump via the water unions  
(Otherwise the titanium heat exchanger may be damaged)

### 2. Accessories

---

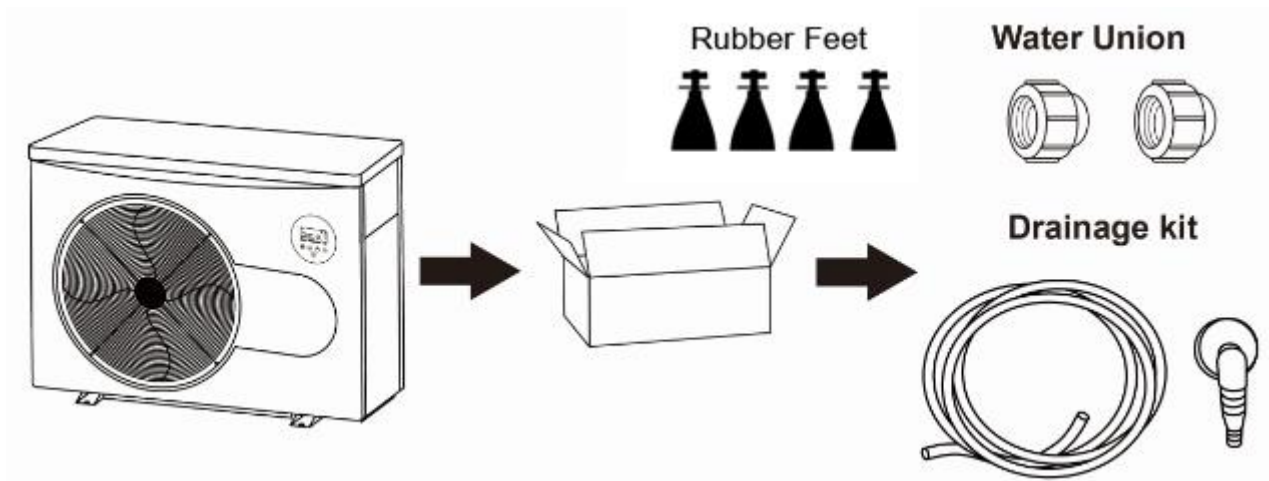

Connection of the condensate drainage kit:

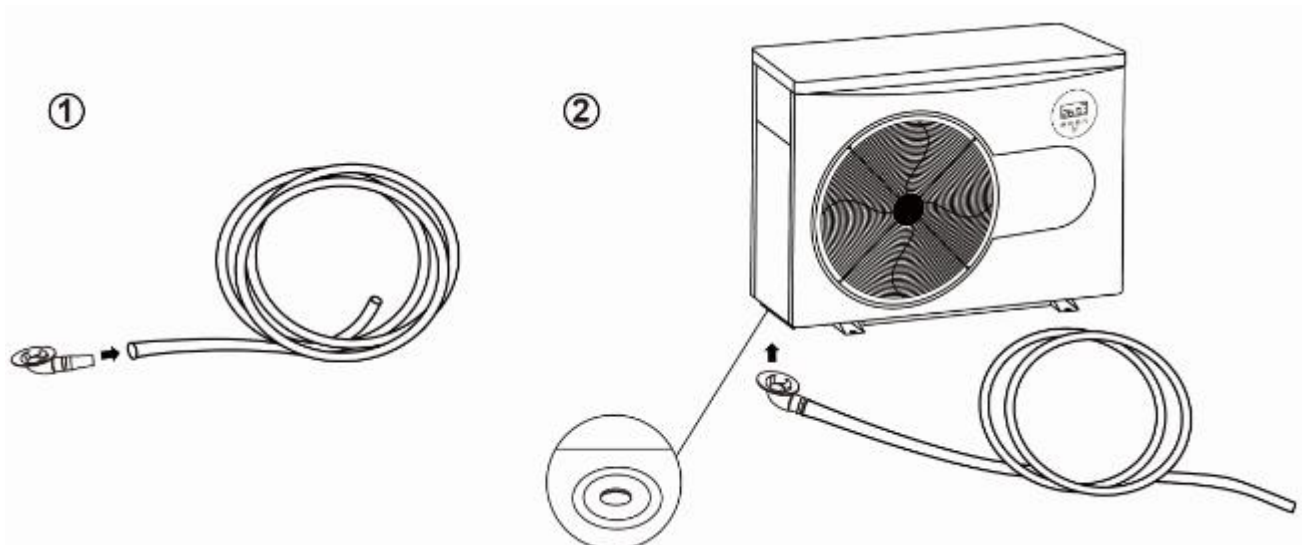

### 3. Features

---

- a) DC Twin-rotary inverter compressor of Mitsubishi
- b) DC Brushless fan motor
- c) EEV Technology
- d) Reverse cycle defrosting with 4-way valve
- e) High-efficiency twisted titanium heat exchanger
- f) Sensitive and accurate temp control and water temp display
- g) High pressure and low-pressure protection
- h) Full protection on electrical system

### 4. Operating range

---



To provide you comfort and pleasure, please set swimming pool water temperature efficiently and economically.

The heat pump air temperature operation range is  $-10^{\circ}\text{C} \sim 43^{\circ}\text{C}$ , and its ideal operation for best performance is operation range between air  $15^{\circ}\text{C} \sim 25^{\circ}\text{C}$ .

### 5. Introduction of different modes

---

- a) The heat pump has two modes: Boost and Silence.
- b) They have different strengths under different conditions.

Mode	Modes	Strength
	Boost mode	Heating capacity: 20% to 100% capacity Intelligent optimization Fast heating
	Silence mode	Heating capacity: 20% to 80% capacity Sound level: 3dB (A) lower than Boost mode

## 6. Technical parameter

---

Model	SME090	SME013	SME016	SME020	SME024
PERFORMANCE CONDITION: Air 27°C/ Water 27°C/ Humid. 80%					
Heating capacity (kW)	9.0	13.0	16.0	20.2	24.2
COP Range	13.2~6.4	13.5~6.5	13.5~6.4	13.5~6.3	13.8~6.5
Average COP at 50% Speed	9.6	9.8	9.5	9.6	9.6
PERFORMANCE CONDITION: Air 15°C/ Water 26°C/ Humid. 70%					
Heating capacity (kW)	6.5	9.0	11.0	14.0	16.0
COP Range	6.9~4.5	7~4.7	7~4.5	7~4.5	7.2~4.8
Average COP at 50% Speed	6.3	6.4	6.2	6.2	6.4
TECHNICAL SPECIFICATIONS					
Advised pool volume (m <sup>3</sup> ) *	20~45	35~65	40~75	50~90	60~110
Operating air temperature (°C)	-5°C~43°C				
Heat exchanger	Twisted Titanium Heat Exchanger				
Power supply	230V 1Ph				
Rated input power (kW)	0.26~1.44	0.34~1.91	0.44~2.44	0.56~3.11	0.60~3.33
Input power at 50% Speed (kW)	0.52	0.70	0.89	1.13	1.25
Rated input current (A)	1.13~6.28	1.50~8.33	1.91~10.63	2.43~13.53	2.61~14.49
Maximum input current (A)	9.5	12.5	17	19.5	20
Power cord (mm <sup>2</sup> )	3x2.5	3x2.5	3x4	3 x 6	3x6
Sound level at 1m dB(A)	39.6~51.5	41.9~52.0	44.2~55.3	44.3~56.1	44.9~56.7
Sound level by 50% speed 1m dB(A)	44.8	47.5	47.7	48.6	49.1
Sound level at 10m dB(A)	19.6~31.5	21.9~32	24.2~35.3	24.3~36.1	24.9~36.7
Advised water flux (m <sup>3</sup> /h)	3~5	4~6	6~8	7~10	10~12
Water connection (mm)	40 mm - 50mm				
Net dimension LxWxH (mm)	872*349*654	872*349*654	962*349*654	962*349*754	961x420x758
Net Weight (kg)	47	49	60	68	68

### Remarks:

This heat pump is able to perform normal within air temp -5° C ~ +43° C, efficiency will not be guaranteed out of this range. Please take into consideration that the pool heat pump performance and parameters are different under various conditions.

Related parameters are subject to adjustment periodically for technical improvement without further notice. For details please refer to nameplate.

## 7. Dimension

---

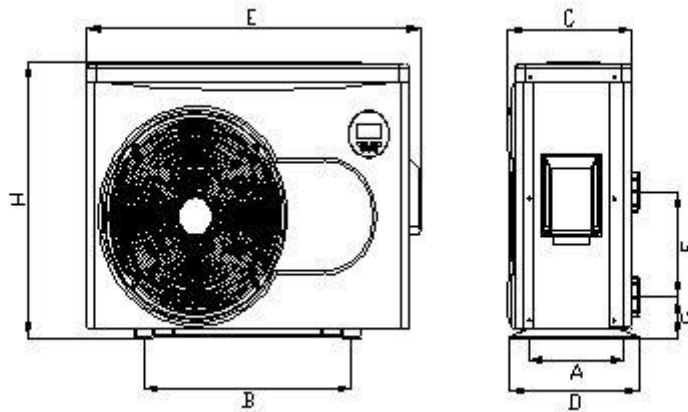

Size(mm) Model	Name	A	B	C	D	E	F	G	H
SME090		324	560	334	349	903	250	74	654
SME130		324	560	334	349	903	320	74	654
SME160		324	590	334	349	991	350	74	654
SME200		324	590	334	349	991	350	74	754
SME240		395	590	401	420	990	460	74	757

※ Above data is subject to modification without notice.

Note: The picture above is the specification diagram of the pool heat pump, for technician's installation and layout reference only. The product is subject to adjustment periodically for improvement without further notice.

## D. Installation guidance

---

### 1. Installation reminder

---

Only competent or professional persons are authorised to install the heat pump. All installations must be installed in line with the relevant building codes and standards of their current state or local governing body for all electrical, mechanical and water services to prevent danger or damage to the heat pump.

#### a. Location and clearances



The inverter pool heat pump should be installed with the required ventilation space.

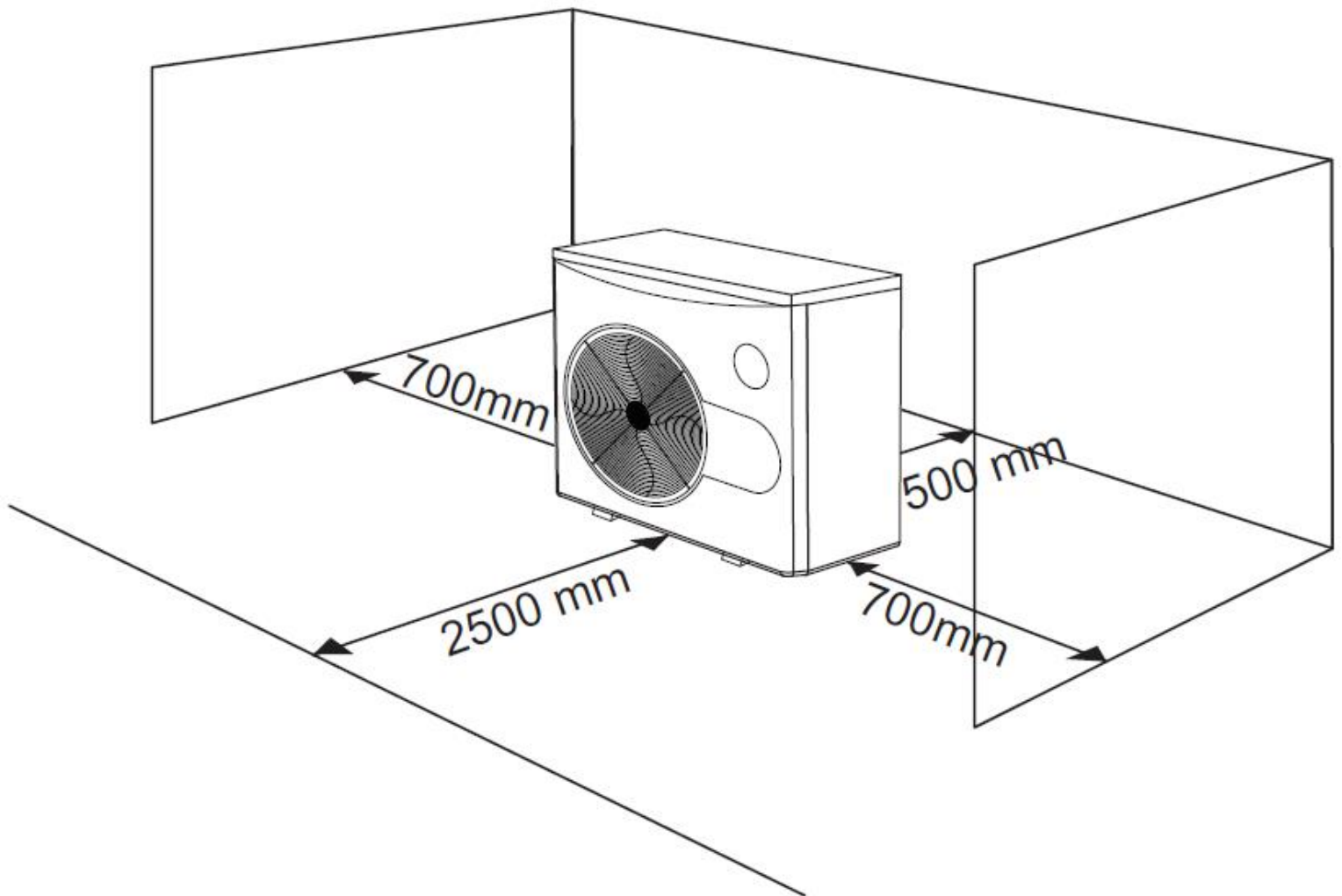

**b. Water pipe connection**



The inlet and outlet water unions must be plumbed in rigid pvc pipes. Flexible hoses must not be used

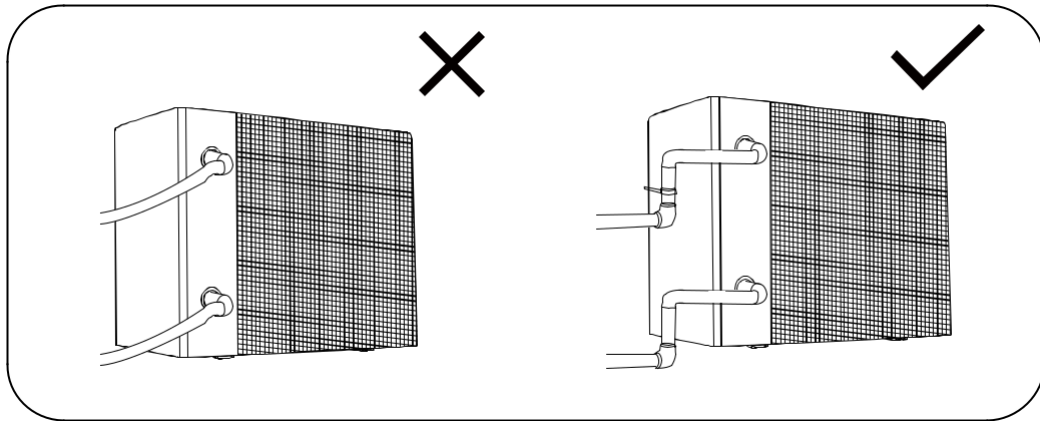

DO NOT install water pipes in a way that they pass behind the heat pumps evaporator.

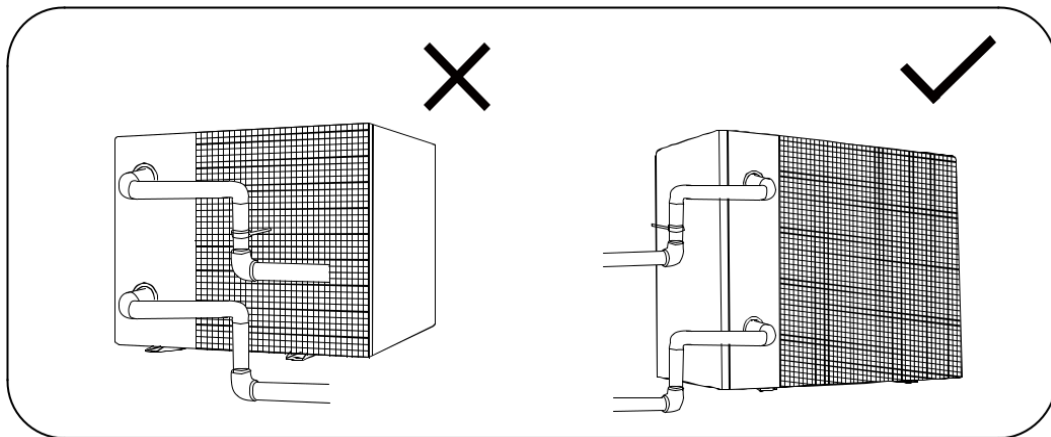

### c. Typical installation diagram

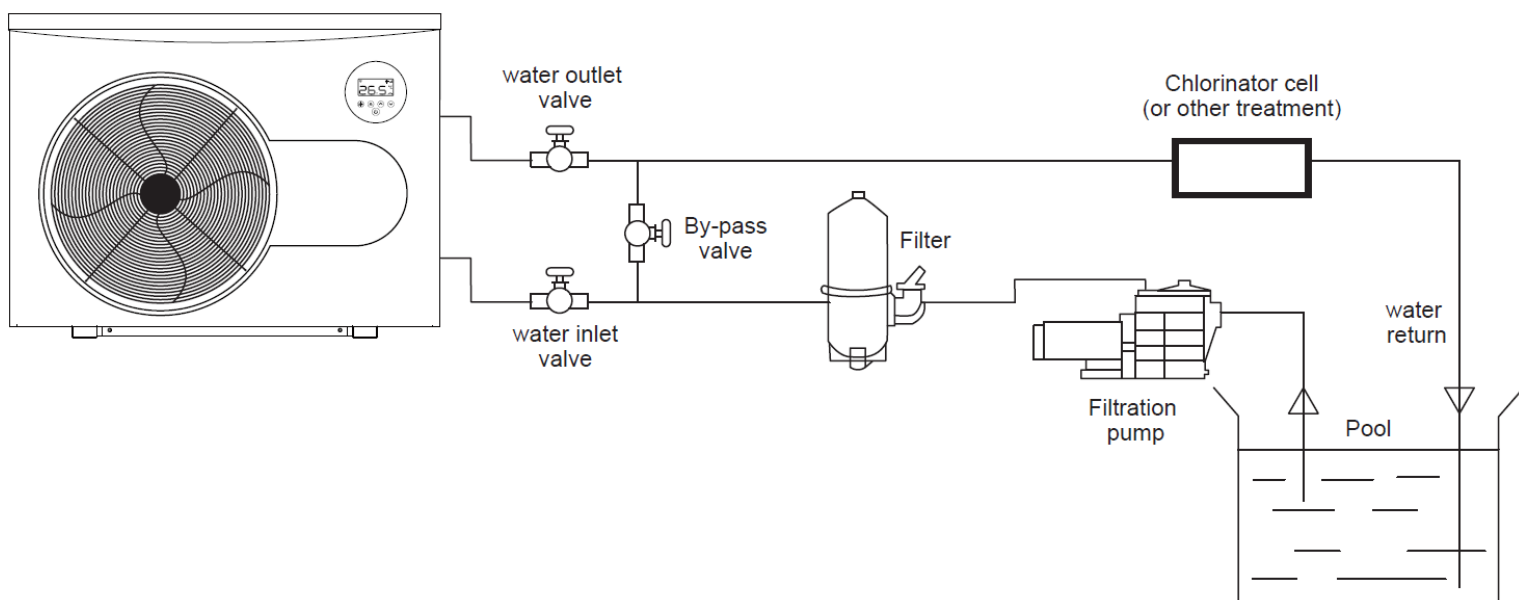

- 1) The heat pump must be securely fixed with the use of the rubber feet (accessory), fixed by bolts (M10) to concrete foundation or fixed to walls by wall brackets. The concrete foundation must be solid and fastened; the bracket must be strong enough and antirust treated,
- 2) Do not stack substances that will block air flow near the inlet or outlet area, and there should be no obstruction within 50cm behind the heat pump, or the efficiency of the heat pump will be significantly reduced and could damage could occur.
- 3) The heat pump may need an additional water pump (not supplied). The recommended pump must adhere to the specification-flux of the heat pump, refer to the technical parameters,
- 4) When the heat pump is running, there will be condensation water discharged from the bottom, please pay attention to it. Install the drainage nozzle (accessory) into the hole and clip it well, then connect a pipe drain hose to drain the condensation water away for the heat pump.

## 2. Wiring

---

- a. Connect the heat pump to the appropriate power supply, the voltage should comply with the rated voltage of the products.
- b. The machine must be earthed.
- c. Wiring must be handled by a professional technician according to the circuit diagram.
- d. You must install an electrical protection device according to the local code for wiring regulations.
- e. The layout of power cable and signal cable should be orderly and not affecting each other.

### 3. Electric Wiring Diagram

---

#### a. For power supply: 230V 50Hz

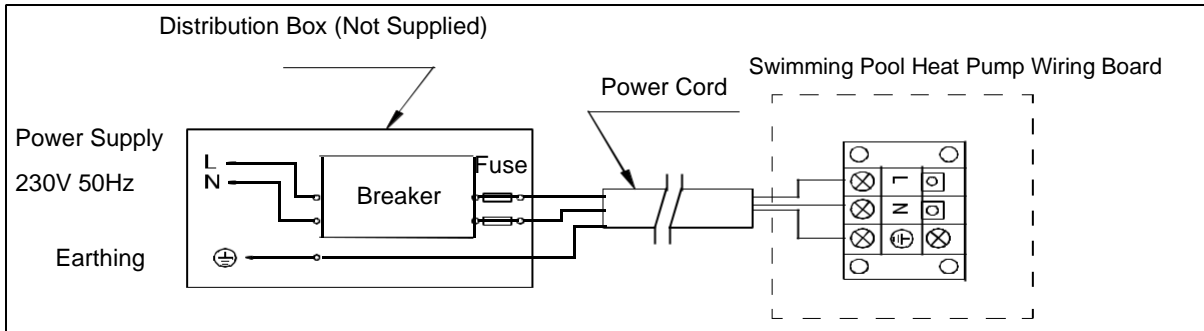

Note:

- 1)  Must be hard wired, plug is not allowed.
- 2) The swimming pool heat pump must be earthed well.

#### 4. References for protecting devices and cable specification

---

MODEL		SME090	SME130	SME160	SME200	SME240
Breaker	Rated Current (A)	9.5	15	20.5	23.5	25
	Rated Residual Action Current (mA)	30	30	30	30	30
Fuse (A)		9.5	15	20.5	23.5	25
Power Cord (mm <sup>2</sup> )		3x1.5	3x2.5	3x4	3x6	3x6
Signal cable (mm <sup>2</sup> )		3x0.5	3x0.5	3x0.5	3x0.5	3x0.5







1. Above data is subject to modification without notice.

**Note:** The data above is associated to power cables less than 10m. If power cable is longer than 10m, the wire diameter must be increased in accordance with current electrical regulations. The signal cable can be extended to a maximum of 50m.

## E. Operation Guidance

### 1. Controller Functions



Symbol	Heating & Cooling Function
	<ol style="list-style-type: none"><li>1. Power On/Off</li><li>2. Wi-Fi setting</li></ol>
	<ol style="list-style-type: none"><li>1. Lock/Unlock Screen</li><li>2. Heating mode (18-40°C)</li><li>3. Cooling mode (12-30°C)</li><li>4. Auto mode (12-40°C)</li></ol>
	<ol style="list-style-type: none"><li>1. Boost </li><li>2. Silence </li></ol>
	Temperature Setting

#### Attention:

- a. The controller has power-down memory function and will not display when locked.
- b. The buttons will turn dark when touchpad is locked.



## 2. Operation Instruction

---



### a. Screen Lock

- 1) Press  for 3 seconds to lock or unlock the screen
- 2) Automatic Lock Period: 30 seconds if no operation

### b. Power On





Press  for 3 seconds to unlock screen. Press  to power on machine.

### c. Temperature Setting

Press  and  to display and set temperature.

### d. Mode Selection

- 1) Heating/Cooling/Auto

Press  to switch to heating , cooling  and auto mode .

Heating mode : Water temperature setting range (18-40°C)



Cooling mode : Water temperature setting range (12~30°C)

Auto mode : Water temperature setting range (12~40°C)

\* When water inlet temperature is higher than setting point, automatic cooling mode starts.

\* When water inlet temperature is lower than setting point, automatic heating mode starts.



- 2) Silence/Boost mode selection



Press  to switch among boost mode , silent mode 

Default mode: boost 

Please choose boost mode  for initial heating





### e. Wi-Fi DOWNLOAD InverGo App from App stores then follow instruction

When the screen is on (unlocked) , press and hold for 3 seconds, after the wifi symbol  flashes, enter Wi-Fi connection. Connect Wi-Fi on mobile phone and input password, and then control equipment by Wi-Fi. When APP connects Wi-Fi successfully,  lights on.

NOTE: To clear the Wi-Fi setting history on the heat pump, when the screen is on, press and hold the  power button for 10 seconds,  Wi-Fi symbol will flash fast for 10 seconds then switch off.





### f. Defrost Cycle

When the heat pump is operating at low temperatures it is very common for ice to build up on the external coil. The heat pump has a built in defrost protection program which will activate when it senses ice starting to form.

- 1) Automatic defrosting: When the heat pump is auto defrosting,  will flash, and return to previous working mode when it finishes.
- 2) Manual Forced Defrosting: To enter forced defrosting mode, the compressor must be working more than 10 minutes. in heating mode, press "" and "" on touch controller simultaneously for 5 Seconds to start forced defrosting, when  is flashing and defrost starts, When  stop flashing and defrosting has stopped.

(Attention: the interval between manual defrosting should be more than 30 minutes.)

### g. Round Controller Running Status Checking

1. Press "" for 5 seconds, it will enter running status mode.
2. During this time, the display will show the status symbol "C0" and its corresponding value.
3. Change status through "" and "", the corresponding value also changes.
4. Press "" to quit "Running Status Checking" mode
5. Running status checking table:





Symbol	Content	Unit
C0	Inlet water temp	°C
C1	Outlet water temp	°C
C2	Ambient temp	°C
C3	Exhaust gas temp	°C
C4	Evaporator coil pipe temp	°C
C5	Return gas temp	°C
C6	Cooling coil pipe temp	°C
C9	Cooling plate temp	°C
C10	EEV opening angle	P

6. Temperature display conversion (Celsius/Fahrenheit)





When the screen is on, Press "" and "" simultaneously for 5 seconds to switch the display between degrees Celsius and degrees Fahrenheit.

**Note: The controller has power-down memory function.**

## Parameters Settings | Checking

1. Press “” and “” together for 5 seconds to enter “parameter checking” status, parameter code “P0” will blink on the left, parameter value “2” will display on the right.
2. Press “” Key and “” Key to check the parameters.
3. Press “” key to exit "parameter checking" status.

### Modifying parameters

4. In "parameter checking" status, press “” to enter "parameter setting" status. At this moment the “parameter value” will blink.
5. In "parameter setting" state, press “” and “” to change the parameters value
6. Press “” to confirm and return to the previous status; Or press “” key to quit and return to the previous status.

Parameter Table

NO.	Content	Adjust range	Step length	Default
P0	Water pump running way	0 : Continuation 1 : Water temp control 2 : time/water temp control	1	2
P1	Time setting ( only available when the water pump running way is set to “2”	10 ~ 120 min	5 min	60 min
P2	Compressor continuously running time in defrosting mode	30 ~ 90min	1min	35 min
P3	Defrosting start temp	-17 ~ 0°C	1°C	-7°C
P4	Defrosting running time	1 ~ 12min	1min	12 min
P5	Defrosting quit temp	8 ~ 30°C	1°C	13°C
P6	Single pump option	On/off 0 ~ 100	1	off
P10	Compressor speed control	0 : Auto, 1 : Manual	1	0
P12	Electronic expansion valve overheat level (heating)	-10 ~ 20	1	3
P13	Electronic expansion valve overheat level (cooling )	-10 ~ 20	1	5
P14	Electronic expansion valve manual/auto	0 : Auto, 1 : Manual	1	0
P15	Electronic expansion valve opening setting (heating)	50 ~ 240	2P	175 (H5)
P16	Electronic expansion valve opening setting (cooling)	50 ~ 240	2P	175 (H5)
P20	Power off memory function	0 — NO, 1 — YES	1	1

## F. Testing

---

### 1. Inspect heat pump before use

---

- a. The air inlets and outlets are operating correctly and are free of debris and obstructions.
- b. It's prohibited to install refrigeration pipe or components in corrosive environment.
- c. Inspect the electric wiring is correctly connected to the electrical schematic.
- d. Inspect for water leaks around unions and heat pump base.

### 2. Refrigerant leak detection

---



- a. Leakage checking is prohibited in closed area.
  - b. Any ignition sources are prohibited during the leakage inspection. A halide torch (or any other detector using a naked flame) shall not be used.
  - c. Leakage detection fluids can be used with most refrigerants but the use of detergents containing chlorine shall be avoided as the chlorine may react with the refrigerant and corrode the copper pipe.
  - d. Vacuum the heat pump completely before welding. Welding should only be carried out by professional personnel in service center.
  - e. Please stop immediately if a gas leak occurs and contact your local service center.
- ### 3. Trial Run
- a. The circulation pump must start before the heat pump and stop after the heat pump to avoid any damage occurring to the heat pump.
  - b. Before turning on the heat pump, please check for any water leaks.
  - c. In order to protect the heat pump, the heat pump is equipped with a time lag starting function, the fan will run 1 minute earlier than the compressor when starting the machine, and it will stop running 1 minute later than the compressor when power turns off the heat pump.
  - d. After the heat pump start up, please check for any abnormal noise from the heat pump.

## **G. Commissioning the heat pump**

### **a. Flow Rates**

The heat pump requires optimisation in order for it to achieve high efficiency and trouble free operation. For best performance the heat pump temperature difference between the inlet and outlet temperature should be between 2-3 degrees.

Each heat pump has a minimum flow rate requirement, check the specification table to ensure the circulation pump in use is adequately sized.

Calibrating the flow rate.

By using the running status function on the touch controller, it is easy to calibrate the valves installed for optimum flow rates for the heat pump.

Heat pumps have a built-in flow switch which will deactivate the heating function if not enough water flow is detected. The heat pump has a large operation range, up to a seven-degree differential. If the temperature differential goes above 7 degrees, the built-in flow switch or E6 error will be displayed indicating insufficient water flow has been detected.

### **Recommended procedure to set temperature differential**

1. Open all 2 way & 3 way valves on the by-pass assembly – on the inlet & outlet pipes.
2. Fully close the by-pass and switch the heat pump on to the required temperature.
3. Wait 5 minutes until heat pump is at 100% capacity
4. Check the inlet and outlet temperatures through the touchpad controller (Check “Running status check” in the previous section to obtain C0 and C1 values)
5. Open the by-pass valve (3 way valve) to increase temperature differential (The difference between C0 and C1 values)
6. Close the by-pass valve (3 way valve) to decrease temperature differential (The difference between C0 and C1 values)
7. Once optimum temperature difference (2-3 C) achieved lock position of the by-pass (3 way valve) if possible.

## H. Maintenance

---



**“SWITCH OFF”** power supply of the heat pump before cleaning, examination and repairing

1. In the winter season when the heat pump is not in operation for long periods of time,
  - a. Switch off the power supply to prevent any machine damage.
  - b. Drain water completely of the heat pump.

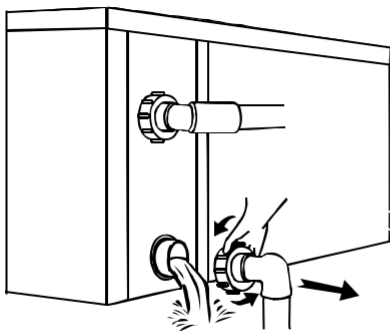

**!!Important:**

Unscrew the water nozzle of inlet pipe to let the water flow out.

*When the water in heat pump freezes in winter season, the titanium heat exchanger may be damaged.*

2. Clean the heat pump with household detergents or clean water, NEVER use gasoline, thinners or any similar fuel.
3. Check bolts, cables and connections regularly.
4. If repairs or removal is required, please contact an authorized service center.
5. Do not attempt to work on the equipment by yourself. Improper operation may cause danger.
6. To reduce risks, safety inspection must be carried before the maintenance or repairing for heat pumps with R32 gas.

## H. Trouble shooting for common faults

---

### 1. Repairing Guidance

---



**WARNING:**

If repair or removal is required, please contact an authorized service center.

Requirements for Service Personnel

- a. Any person who is involved with working on or breaking into a refrigerant circuit should hold a current valid certificate from an industry-accredited assessment authority, which authorizes their competence to handle refrigerants safely in accordance with an industry recognized assessment specification.
- b. Do not attempt to work on the equipment by yourself. Improper operation may cause danger.
- c. Strictly comply with the manufacturer's requirements when charging R32 gas and equipment maintenance. This chapter focuses on special maintenance requirements for swimming pool heat pump with R32 gas. Please refer to the technical service manual for detailed maintenance operation.
- d. Vacuum system completely before welding. Welding should only be carried out by professional person in a service center.

### 2. Failure solution and code

---

Failure	Reason	Solution
<b>Heat pump doesn't run</b>	No power	Wait until the power recovers
	Power switch is off	Switch on the power
	Fuse burned	Check and change the fuse
	The breaker is off	Check and turn on the breaker
<b>Fan running but with insufficient heating</b>	Evaporator blocked	Remove the obstacles
	Air outlet blocked	Remove the obstacles
	3 minutes start delay	Wait patiently
<b>Display normal, but no heating</b>	Set temp. too low	Set proper heating temp.
	3 minutes start delay	Wait patiently
If above solutions don't work, please contact your installer with detailed information and your model number. Don't try to repair it yourself.		

**Note:** If the following conditions happen, please stop the machine immediately, and switch off the power supply immediately, then contact your dealer or local repair center.

1. Inaccurate switch action.
2. The fuse is frequently broken or leakage circuit breaker keeps tripping.

## Protection & Failure code

Error	Which component?	Error detected?	Solutions
E1	High pressure protection	High gas pressure switch	1. Check the water flow from the filtration pump and ventilation clearances. 2. Check high pressure switch is closed circuit 3. Replace PCB 4. replace inverter board
E2	Low pressure protection	Low gas pressure switch	1. Check the water flow from the filtration pump and ventilation clearances. 2. Check low pressure switch is open circuit 3. Replace PCB 4. replace inverter board
E3	No water protection	Low water flowrate	Check the water flow in pipes, and filtration pump is running. Check filters, skimmer basket, back wash. Check the bypass or valves have not been adjusted since commissioned. Check the Water flow switch.
E4	3 phases sequence protection	Electrical power connection	Check the power connection to the pump.
E5	Power supply exceeds operation range (Not failure)		1). Recover when back to the normal power 2). Replace PCB.
E6	Excessive temp difference between inlet and outlet water (Insufficient water flow protection)	High temperature difference	Check the water flow in pipes, and filtration pump is running. Check the bypass is opened and unit is commissioned. Check the Water flow switch.
E7	Water outlet temp too high or too low protection	Water flowrate in pipes	Check if there is any blockage in the inlets, outlets, and through the pipes.
E8	High exhaust temp protection	Compressor overheating	Check if refrigerant gas is leaking, check the connection of the sensor, might need to change if faulty, check the compressor of the pump.
Eb	Ambient temperature too high or too low protection (not failure)	Out of the heat pump's capacity to withdraw heat from the atmosphere	Out of application range.
Ed	Anti-freezing reminder (not failure)		Wait for automatic recovery
F1	Compressor drive module failure	Lack of phase	Check the voltage and the frequency conversion
F2	PFC module failure	PFC circuit	Check the PFC switch circuit if short or not
F3	Compressor start failure	Compressor circuit	Check the compressor wiring if its correct or if there is any short circuit.
F4	Compressor running failure	Compressor circuit	Check the compressor wiring if its correct or if there is any short circuit
F5	Inverter board over current protection		Wiring Inverter board PCB
F6	Inverter board overheat protection	Inverter board high temp	Check the current flowing it might need to be adjusted.

<b>F7</b>	Current protection		Power off and restart Inverter board Compressor
<b>F8</b>	Cooling plate overheat protection		Power off and restart Check fan motor Check cooling plate
<b>F9</b>	Fan motor failed to start	Fan motor	To reset fan motor, either unplug heater from power point or OFF & ON RCD in electrical meter box. Check the fan motor wiring, check if the fan is broken or loose
<b>Fb</b>	Power filter plate No-power protection	Power filter not working	Single Phase Model Replace Inverter board 3 Phases Model Replace power filter plate
<b>FA</b>	PFC module over current protection	Solar inverter voltage change Power black out Power surge	Initial power testing has completed. Power off and restart (happens install with solar PV) Replace Inverter board
<b>P1</b>	Water inlet temp sensor failure	The water inlet temperature sensor is either damaged or running a short circuit	Check the Temperature sensor at the water inlet, might need to be changed.
<b>P2</b>	Water outlet temp sensor failure	The water outlet temperature sensor is either damaged or running a short circuit	Check the Temperature sensor at the water outlet, might need to be changed.
<b>P3</b>	Gas exhaust temp sensor failure	The sensor is running a short circuit, damaged, or not fixed properly	Check the gas exhaust, temperature sensor, might need a replacement.
<b>P4</b>	Evaporator coil pipe temp sensor failure	The sensor is running a short circuit, damaged, or not fixed properly	Check the evaporative coil pipe Temperature sensor, might need a replacement.
<b>P5</b>	Gas return temp sensor failure	The sensor is running a short circuit, damaged, or not fixed properly	Check the Gas return Temperature sensor, might need a replacement.
<b>P6</b>	Cooling coil pipe temp sensor failure	The sensor is running a short circuit, damaged, or not fixed properly	Check the cooling coil pipe Temperature sensor, might need a replacement.
<b>P7</b>	Ambient temp sensor failure	The sensor is running a short circuit, damaged, or not fixed properly	Check the Ambient Temperature sensor, might need a replacement.
<b>P8</b>	Cooling plate temp sensor failure	The sensor is running a short circuit, damaged, or not fixed properly	Replace inverter board.
<b>P9</b>	Current sensor failure	The sensor is running a short circuit, damaged	Replace inverter board for single phase model Replace power filter plate for 3 phases model



# I. Water pump control connection

Water pump: 230V voltage,  $\leq 500W$  capacity

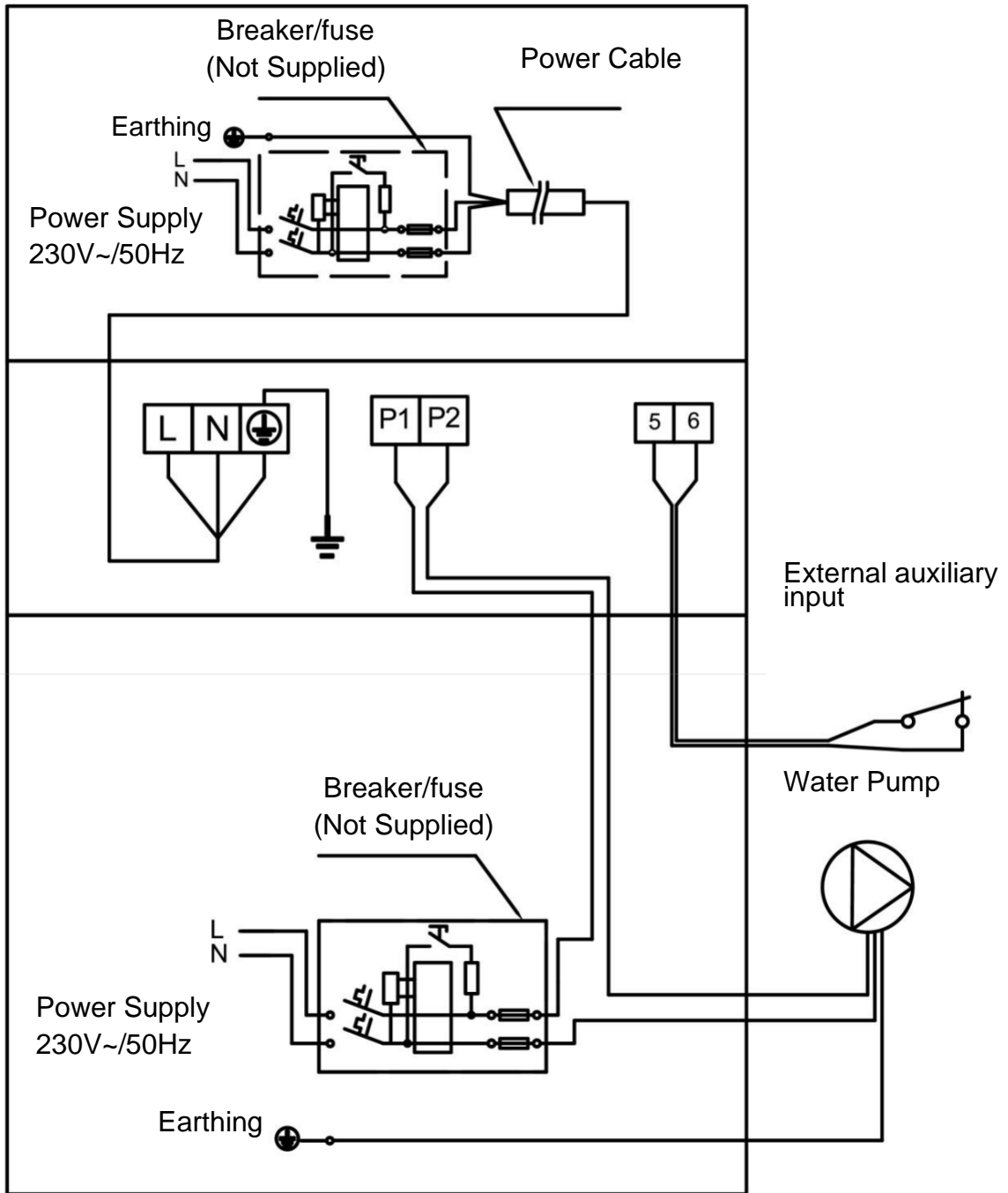

Water pump: 230V voltage, >500W capacity

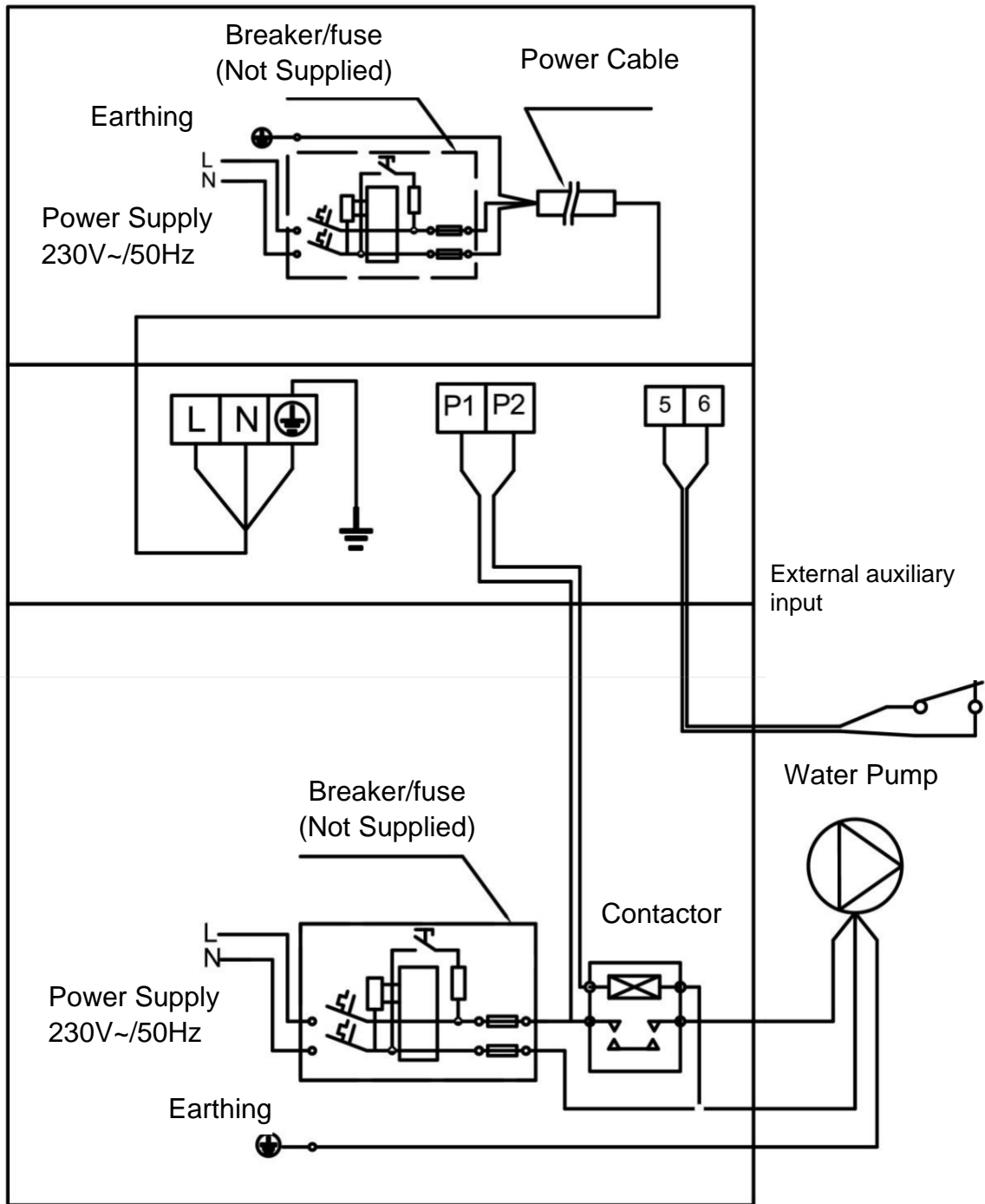

## Water pump control and timer connection

1: Water pump timer

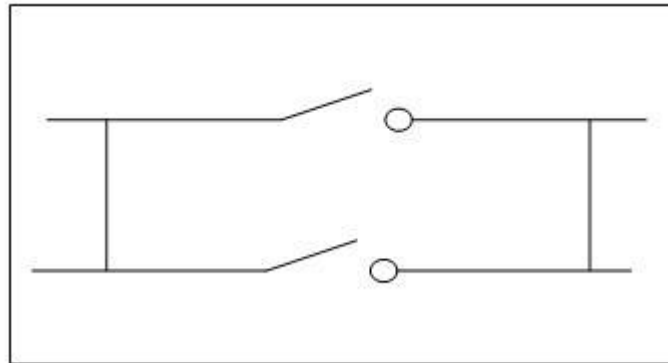

2: Water pump wiring of Heat Pump

Note: The installer should connect 1 parallel with 2 (as above picture). To start the water pump, condition 1 or 2 is connected. To stop the water pump, both 1 and 2 should be disconnected.

## J. Wi-Fi Operation

Follow the instructions below to connect a smart phone to the heat pump via a Wi-Fi network. It is crucial that the Wi-Fi network signal strength is of high power at the heat pump location otherwise connection will not be achieved.

### 1 APP Download



Android please download from



iOS please download from



### 2 Account Registration

1. Register by mobile or E-mail.

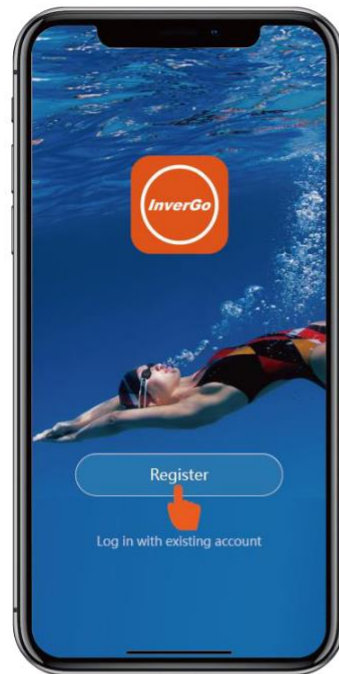

2. Mobile or E-mail registration.

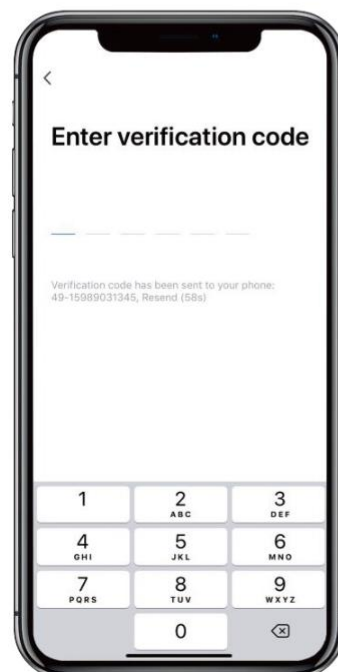
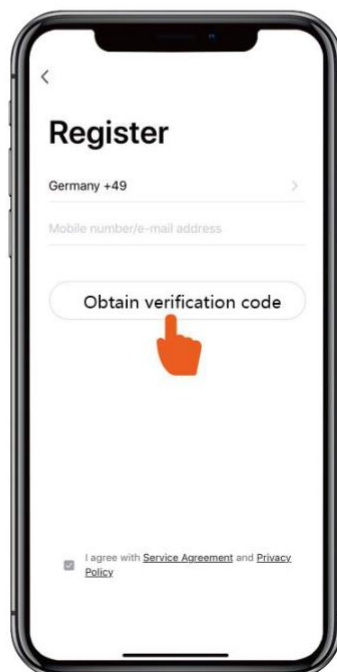

### 3 Create Family

Please set family name and choose the room of device.

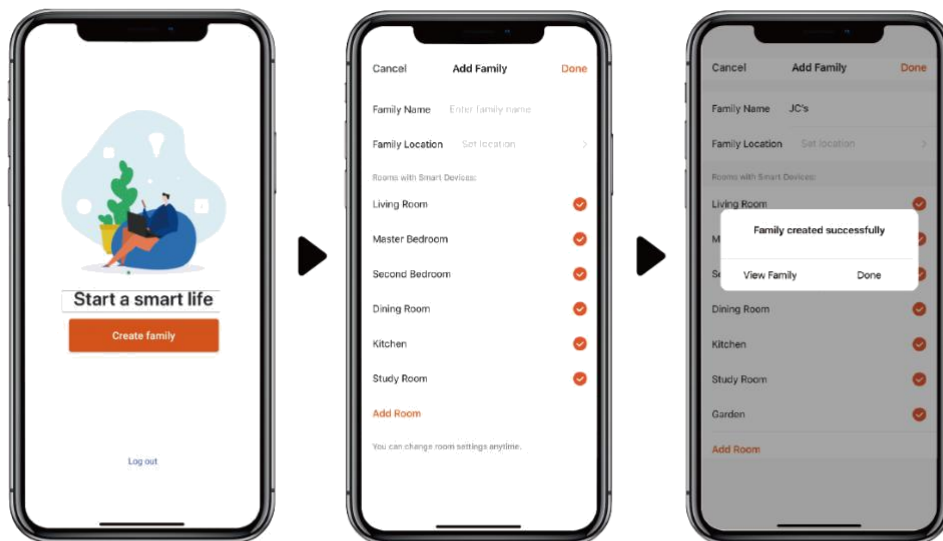

### 4 APP Pairing

Please make sure you are connected to the Wi-Fi.

1. Press “ M” for 3 seconds to unlock the screen, press “ ” for 3 seconds then release, after hearing “Beep”, enter Wi-Fi password in APP. During connection, “ ” flashes, when the APP connects to the Wi-Fi successfully, “ ” will display.



2. Click "Add Device", and then follow instructions to pair device.

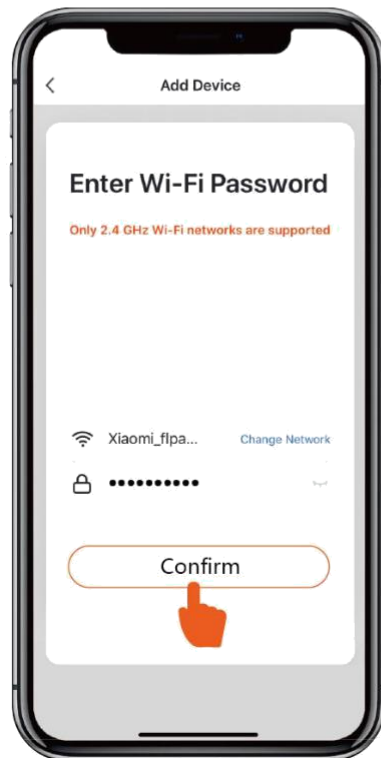
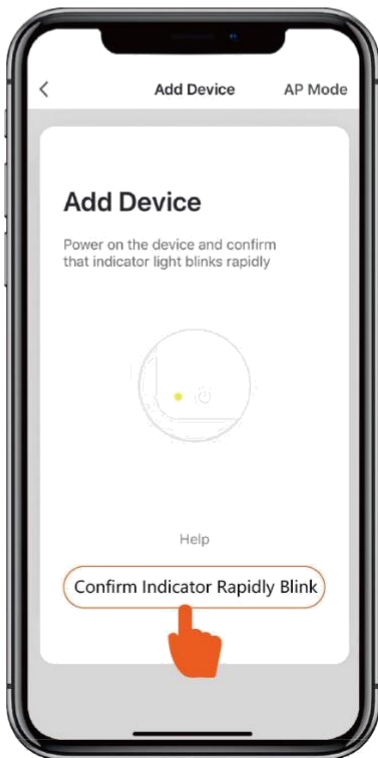
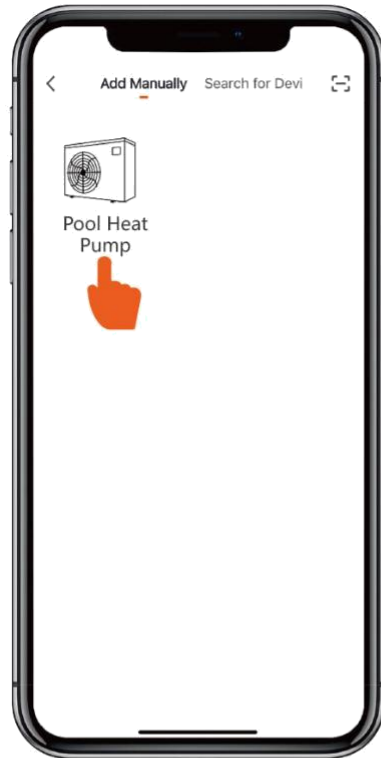
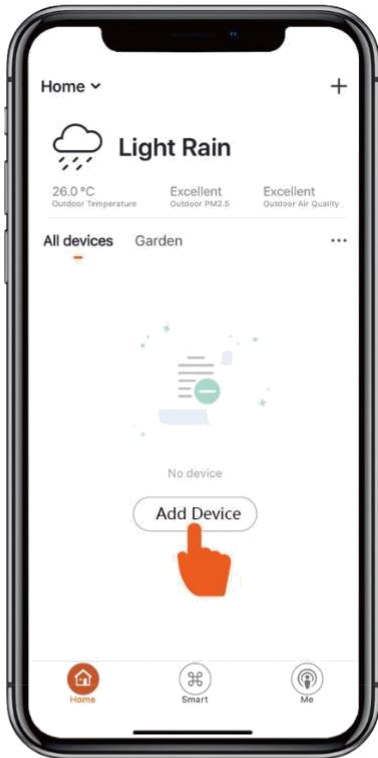

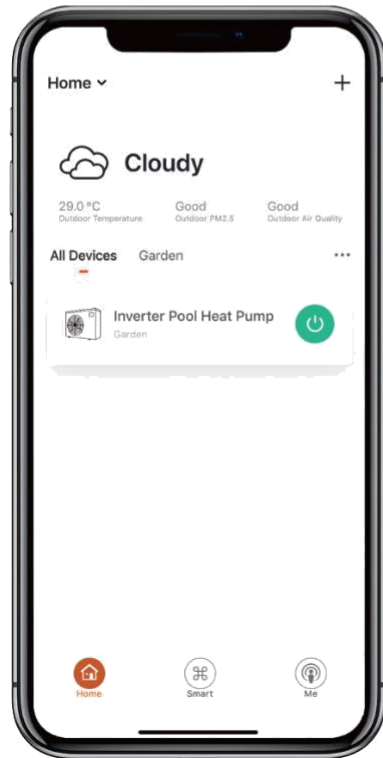
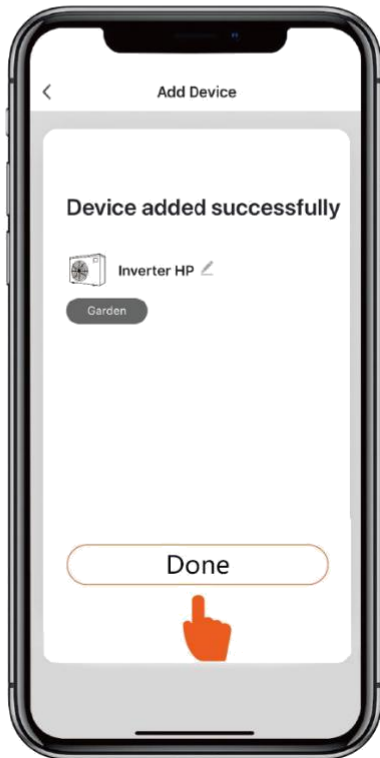
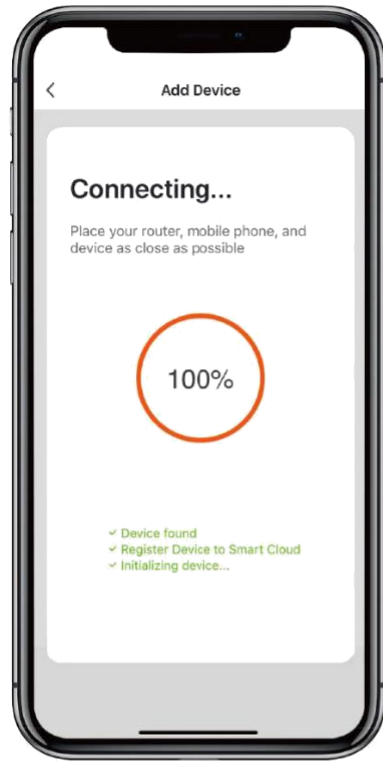
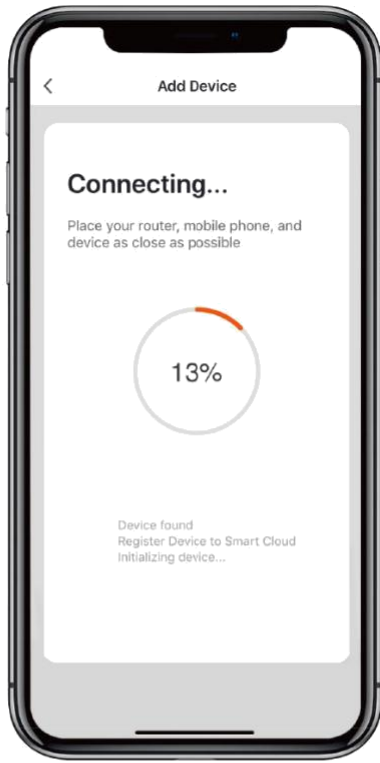

## 5 Operation

1. For heat pump with Heating function only :



2. For heat pump with Heating&Cooling function :



## 6 Share Devices to Your Family Members

After pairing, if your family members also want to control the device. Please let your family members register the APP first, and then the administrator can operate as below:

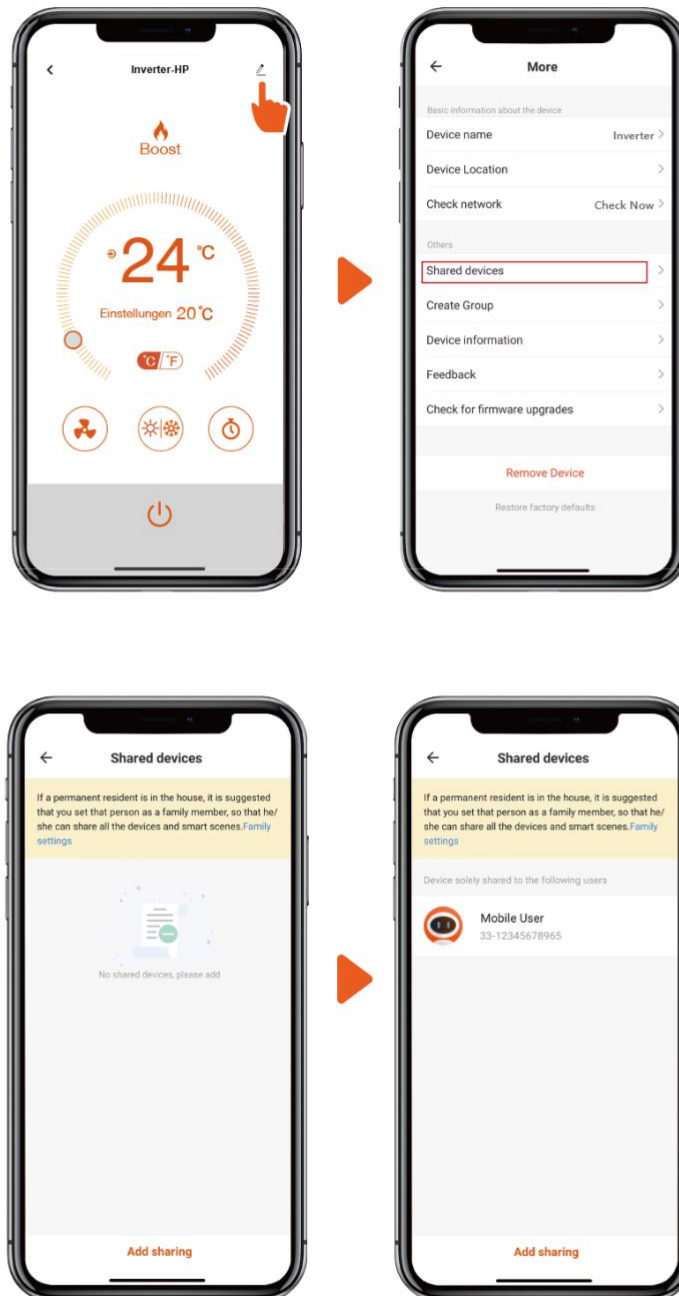

Notice: The weather forecast is just for reference.  
App is subject to updating without notice.

EZIHEAT AUSTRALIA PTY LTD

ABN 11 158 163 298

Phone: 1300 363 555 Web: [eziheat.com.au](http://eziheat.com.au) Email: [info@eziheat.com.au](mailto:info@eziheat.com.au)